

SURGE VESSELS

ADVANCED WATER HAMMER PROTECTION SYSTEMS

Engineered to protect pipelines,
stabilize pressure and ensure
uninterrupted system
performance.

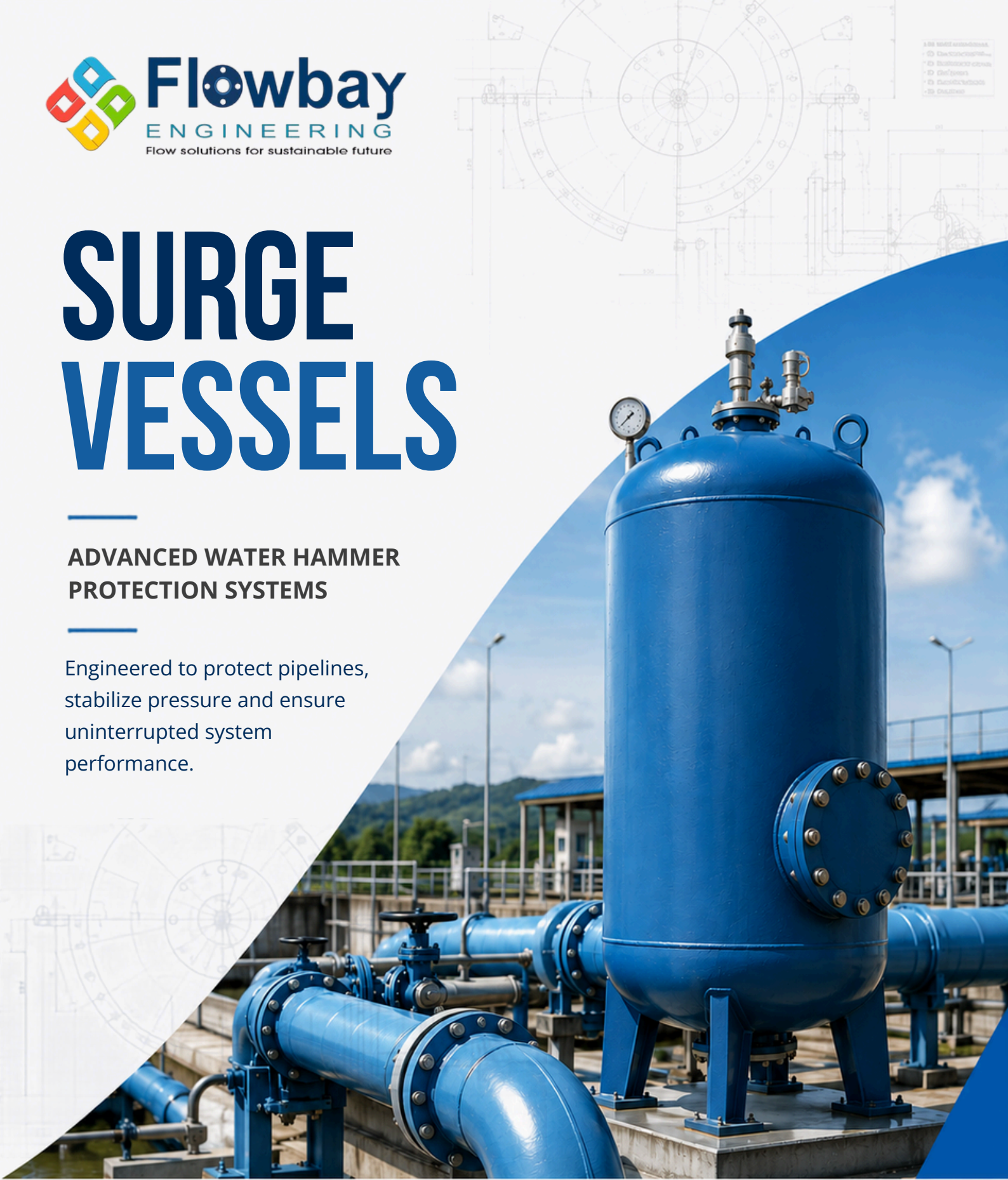

MUNICIPAL
WATER SUPPLY



PUMPING
STATIONS



INDUSTRIAL
NETWORKS



IRRIGATION
SYSTEMS



PROTECTING
CRITICAL
PIPELINE
INFRASTRUCTURE

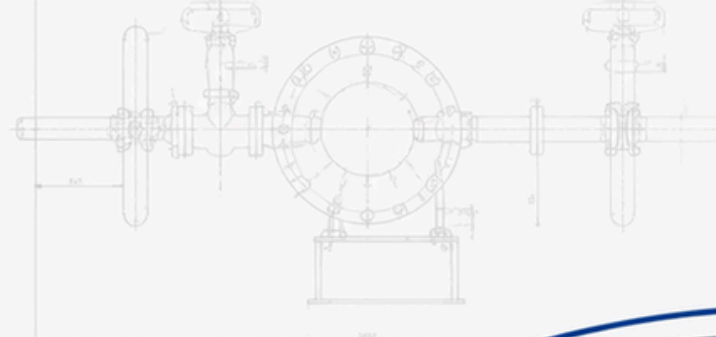

ADVANCED SURGE PROTECTION FOR CRITICAL PIPELINE SYSTEMS

Flowbay Engineering provides engineered Surge Vessel solutions designed to protect water transmission pipelines, pumping mains, industrial utility networks, and irrigation systems from damaging hydraulic transients commonly known as water hammer.

A Surge Vessel acts as a hydraulic buffer by absorbing excessive pressure during surge events and supplying water back into the system during pressure drops. This helps maintain pipeline integrity, protects pumping equipment, and ensures uninterrupted system performance.



PROTECTS PIPELINES



PROTECTS PUMPING EQUIPMENT



MAINTAINS PIPELINE INTEGRITY







ENSURES UNINTERRUPTED SYSTEM PERFORMANCE

WHAT IS WATER HAMMER?

Water hammer is a transient pressure phenomenon caused by sudden changes in flow velocity within a pipeline system.

IT COMMONLY OCCURS DUE TO:

-  Pump trip or power failure
-  Sudden valve closure or opening
-  Rapid pump startup or shutdown
-  Flow reversal conditions
-  Emergency operating events

UNCONTROLLED WATER HAMMER CAN RESULT IN:

-  Pipeline rupture
-  Excessive positive pressure
-  Vacuum conditions and pipe collapse
-  Pump and valve damage
-  Joint failure and leakage
-  Increased maintenance costs

Proper surge protection is therefore essential for long transmission mains and pumping systems.

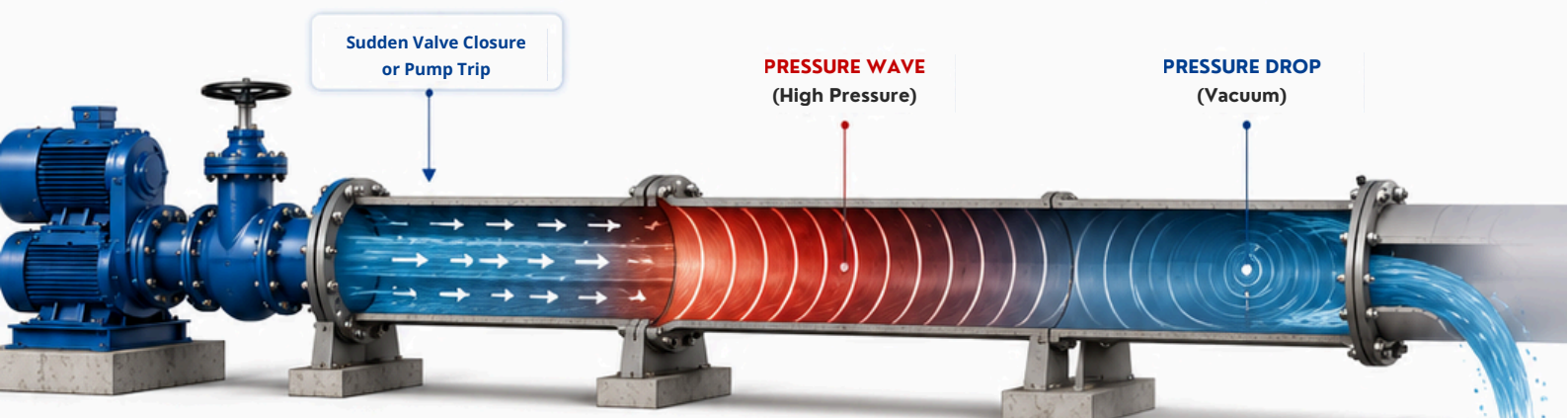

PIPELINE RUPTURE



EXCESSIVE POSITIVE PRESSURE



VACUUM CONDITIONS AND PIPE COLLAPSE



PUMP AND VALVE DAMAGE



JOINT FAILURE AND LEAKAGE



INCREASED MAINTENANCE COSTS

HOW A SURGE VESSEL WORKS

A Surge Vessel is installed at strategic locations within a pipeline system to absorb pressure fluctuations generated during transient events.

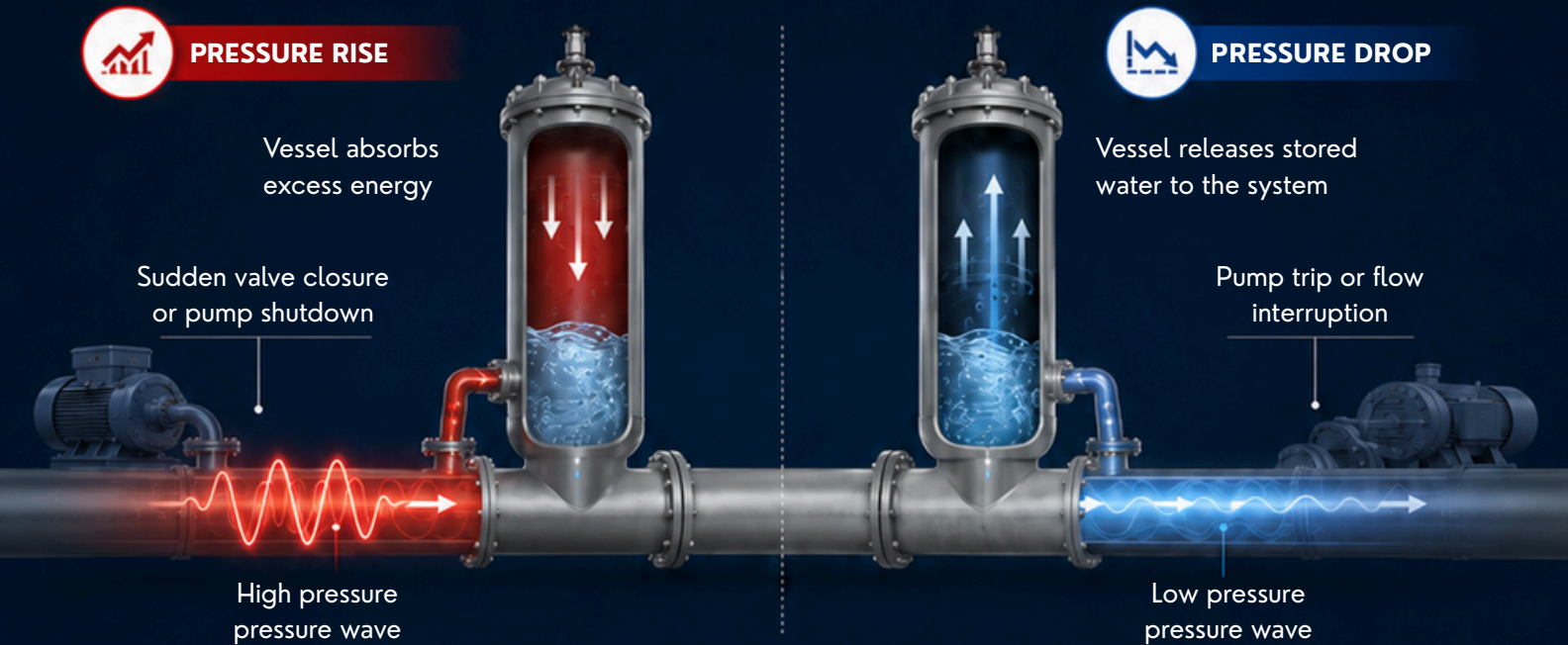

➤ During a sudden pressure rise, the vessel absorbs excess hydraulic energy, reducing surge pressure.

➤ During a sudden pressure drop caused by pump trip or flow interruption, the vessel releases stored water back into the pipeline, preventing vacuum formation and column separation.

FLOWBAY SURGE VESSEL SOLUTIONS



BLADDER TYPE SURGE VESSEL

A bladder-type surge vessel contains a reinforced elastomeric bladder that separates compressed gas from water.

This design prevents air dissolution into the water and provides consistent long-term performance with minimal maintenance requirements. Pre-charge pressure is determined through detailed surge analysis to ensure optimum protection during transient events.

ADVANTAGES

- ✓ Maintenance-friendly operation
- ✓ High operational reliability
- ✓ No air-water mixing
- ✓ Long service life
- ✓ Fast response to transient events
- ✓ Suitable for municipal and industrial applications

FLOWBAY SURGE VESSEL SOLUTIONS

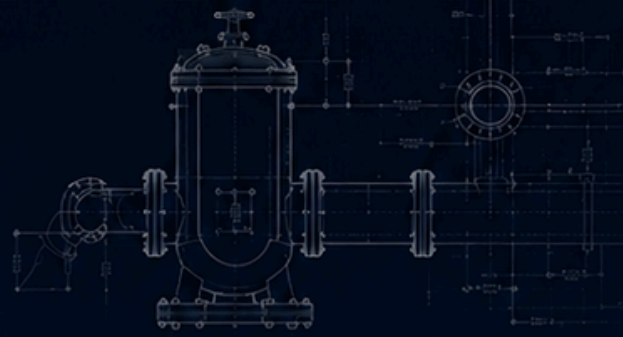

HYDROPNEUMATIC SURGE VESSEL

Hydropneumatic surge vessels utilize a compressed air cushion to absorb and dissipate hydraulic shock waves generated during pipeline operation.

These systems are commonly used in large pumping stations and critical transmission pipelines requiring high-capacity surge protection.

ADVANTAGES

- ✓ Excellent water hammer protection
- ✓ Suitable for large-diameter pipelines
- ✓ Effective pressure stabilization
- ✓ Customizable vessel capacities
- ✓ Reliable long-term operation



WATER HAMMER CONTROL

Protects pipelines from damaging pressure spikes caused by transient hydraulic events.



PUMP PROTECTION

Prevents reverse flow, cavitation, and excessive stress on pumping equipment.



PIPELINE SAFETY

Reduces risk of pipe bursts, joint failures, and structural damage.



PRESSURE STABILIZATION

Maintains stable operating pressures throughout the system.



REDUCED MAINTENANCE COSTS

Minimizes equipment failures and unplanned shutdowns.



IMPROVED SYSTEM RELIABILITY

Enhances overall operational performance and asset life.

KEY BENEFITS

TYPICAL APPLICATIONS

FLOWBAY SURGE VESSEL SYSTEMS ARE SUITABLE FOR:



Municipal Water Supply Projects



Drinking Water Transmission Mains



Pumping Stations



Lift Irrigation Schemes



Wastewater Rising Mains



Industrial Utility Networks



Cooling Water Systems



Fire Water Networks



Desalination Plants



Process Water Pipelines



These applications benefit significantly from surge protection where pump trips, power failures, long pipelines, or rapid valve operations are expected.

ENGINEERING & DESIGN APPROACH

Every surge vessel must be sized based on a detailed hydraulic transient analysis rather than a standard rule of thumb.

FLOWBAY ENGINEERING EVALUATES:

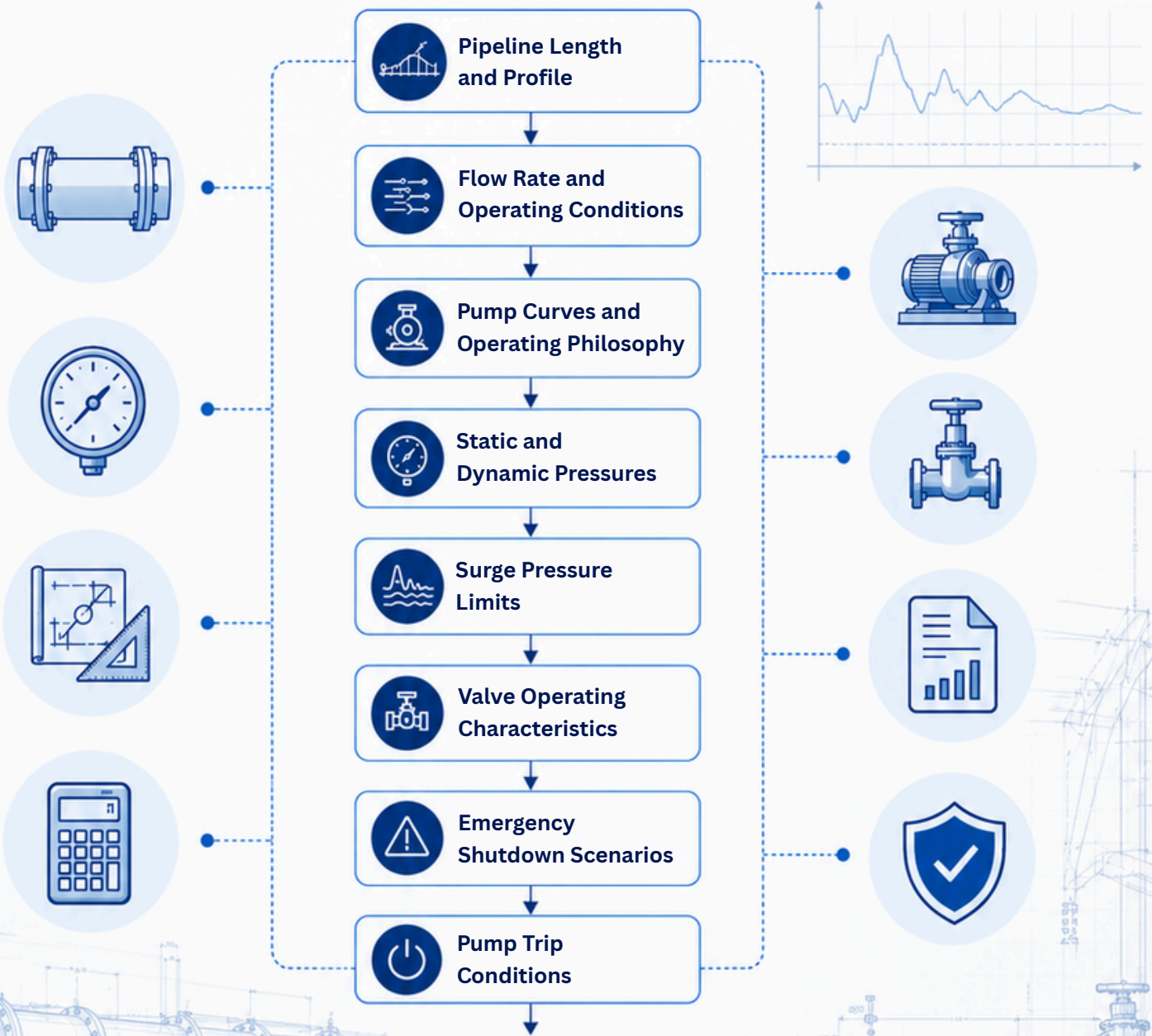

Based on the surge analysis, the appropriate vessel type, volume, pre-charge pressure, and instrumentation package are selected for optimal performance.

